

1. 基本信息

设备编号	3125-00006
编号类型	内部编号
设备型号	M900D
建档日期	2017-10-18 14:04:16
备案有效期	2018-10-18 14:04:16
产权单位	上海市机械施工集团有限公司
采购日期	2017-10-17
产地	中国
制造商	FAVCO
臂长	59.6 M
最大起重量	64 T*M
起重卷扬容绳量	600 M
对地压强（地耐力参数）	kg/cm ²
总重量（约）	315 T

2. 结构反力

图1:

□

最大塔身高度 I	
爬距范围 II	

风速 结构反力	工作状态风速	非工作状态风速
	20	42
M		
V	283	239
MK		
H1	83	67
H2	76	37

图2:

□

风速 结构反力	工作状态风速	非工作状态风速
	20	42
M	1456	1178
V	276	225
S	9	37
MK		

T	390	317
U	253	204
结构反力	20	42
风速	工作状态风速	非工作状态风速

图3:

最大塔身高度 II	
爬距范围 I	

风速	工作状态风速	非工作状态风速
结构反力		
M		
V		
MK		
H1		
H2		

3. 爬升框

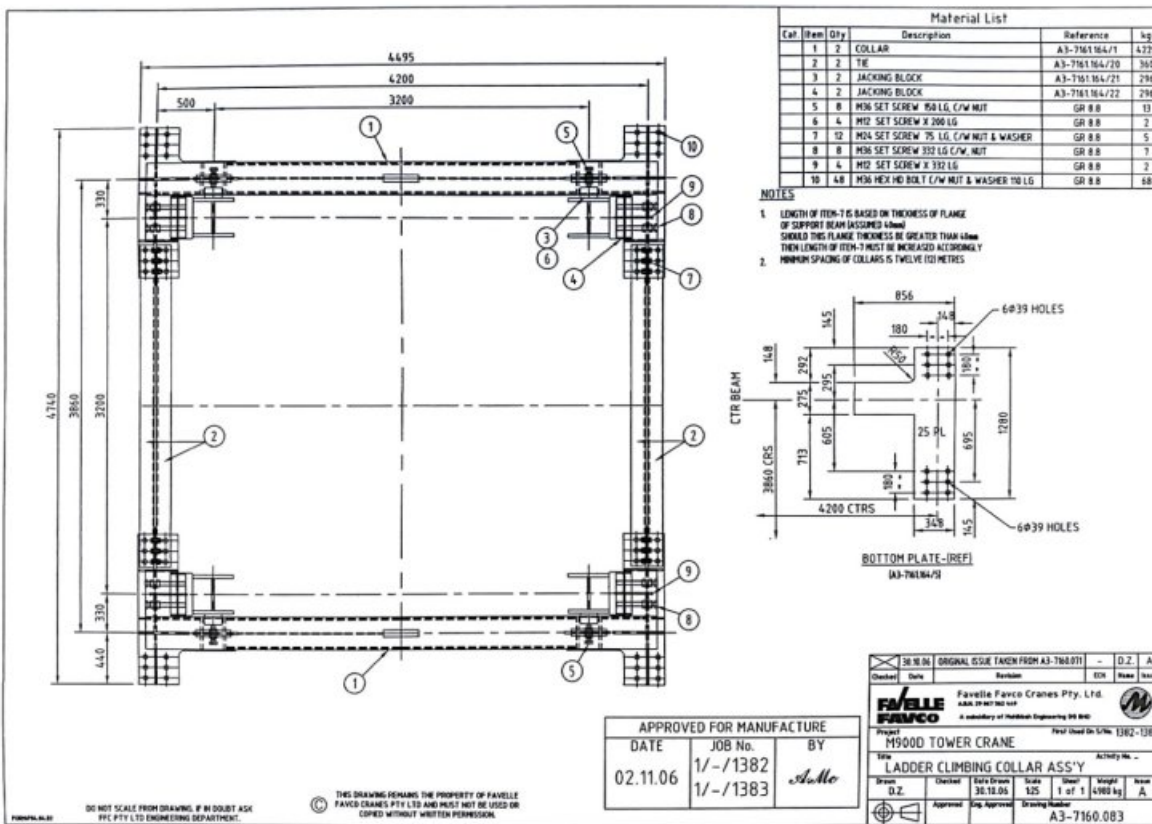

4. 爬带配置

APPROVED FOR MANUFACTURE

DATE 20.10.05

JOB No. 1/-/1250

BY

1/-/1251
A.Mc

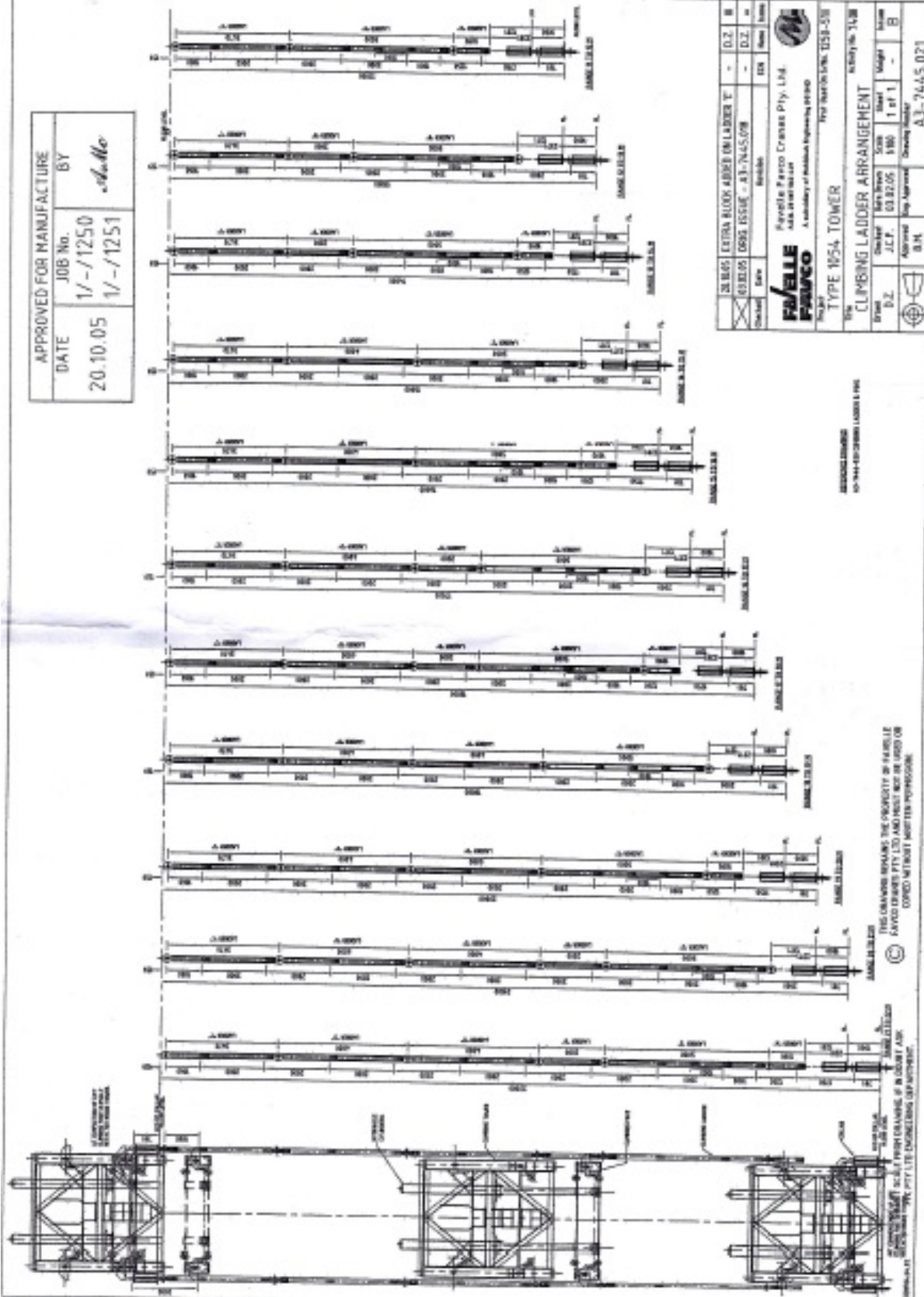

5. 外形尺寸

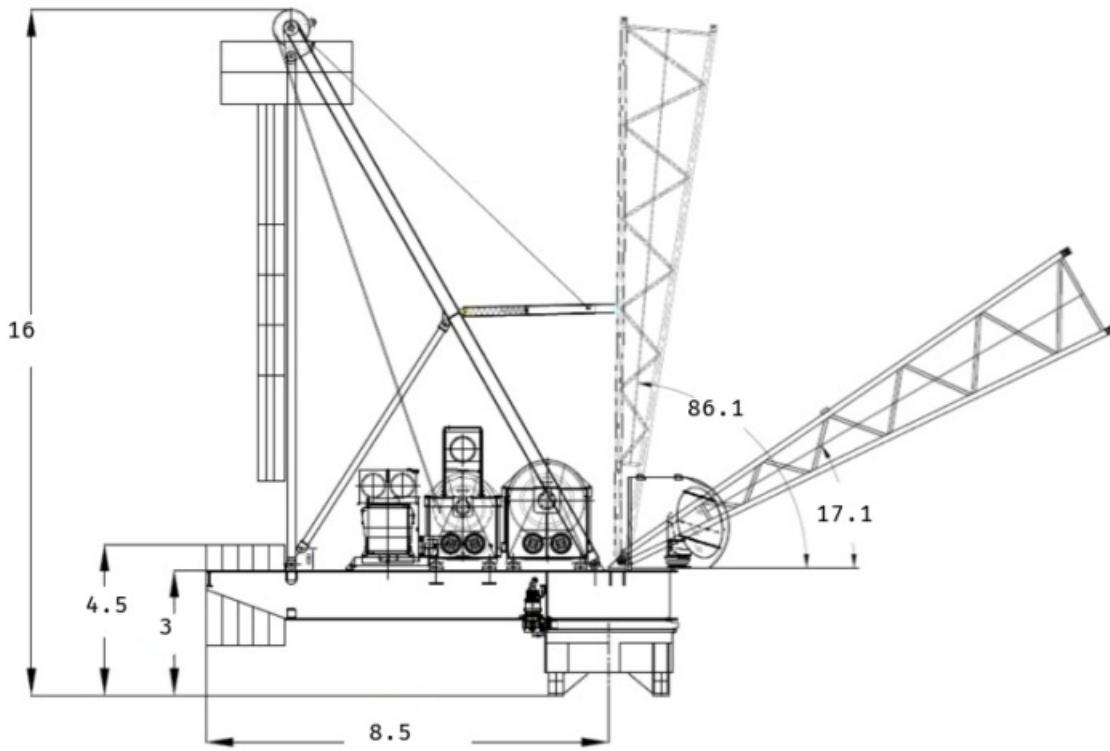

6. 设备清单

名称	数量	单重 (t)	总重 (t)	外形尺寸 (m) 长×宽×高	备注
一、主机部分					
机械平台 (前部)	1	24.8	24.8	10.5×3.5×2.2	
机械平台 (后部)	1	0	0	××	
人字架总成	1	9.7	9.7	14.4×3.22×0.8	
驾驶舱总成	1	1.3	1.3	3.54×3.9×1.8	
动力包	1	24.5	24.5	5.7×2.25×2.25	
下回转	1	7.25	7.25	4.22×2×2	
二、塔节部分					
内顶升节总成	1	17	17	4.2×3.6×3.6	
标准节	13	7.95	103.35	4×3.6×3.6	含两节加强节
顶升套架	3	6	18	××	爬升框

名称	数量	单重 (t)	总重 (t)	外形尺寸 (m) 长×宽×高	备注
三、塔臂部分					
伸臂根节	1	2.8	2.8	13.7×3×3	
伸臂延长节_1	3	2.9	8.7	9.2×3×3	
伸臂顶节	1	3.7	3.7	13.7×3×3	
四、吊索件					
主吊钩	1	3	3	××	64
变幅滑轮组	1	2	2	××	
临时拉索	1	2.5	2.5	××	
五、配重					
配重块	12	6.6	79.2	××	总重不变
			总重量	313.80 吨	

7. 载荷性能曲线及起重性能表

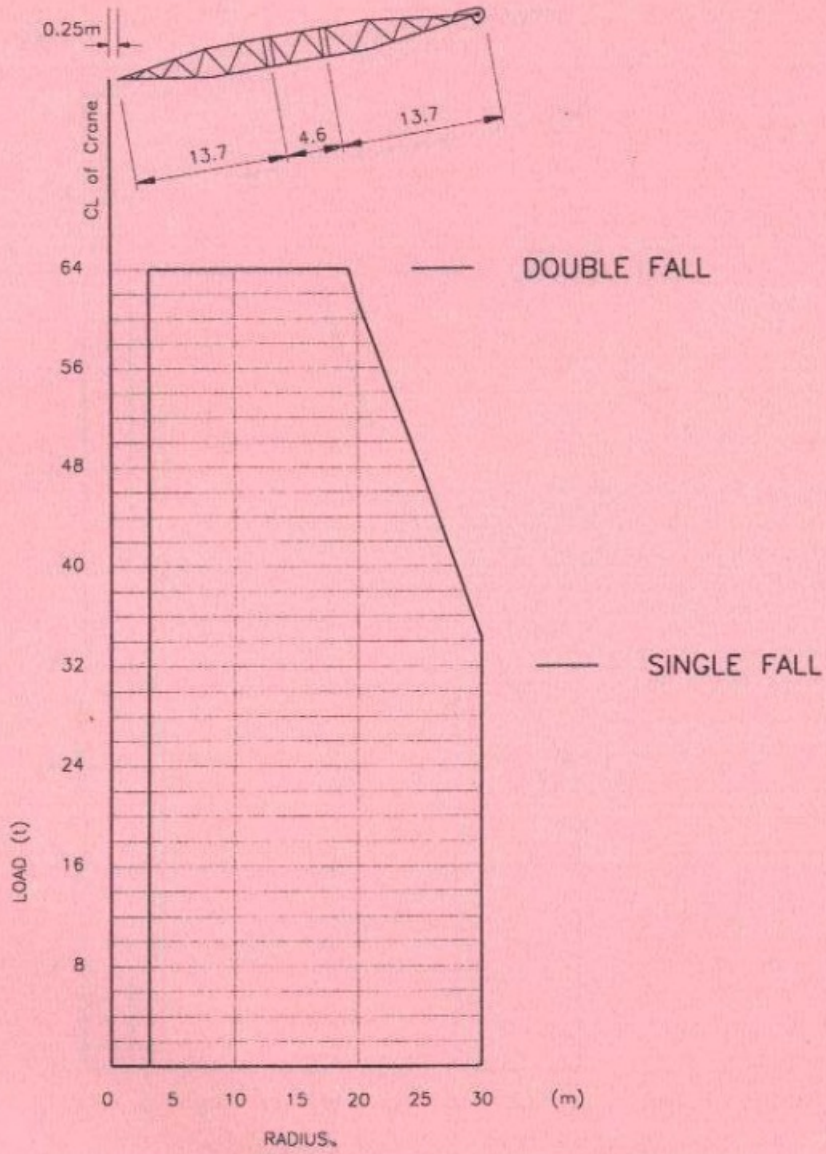

LOAD CHART 30.0m RADIUS BOOM

RADIUS (m)	3.1	10.0	15.0	19.3	20.0	25.0	30.0
LOAD (T)	64.0	64.0	64.0	64.0	61.5	48.2	34.3
BOOM ANGLE (°)	86.0	73.4	63.7	54.7	53.1	40.7	23.5

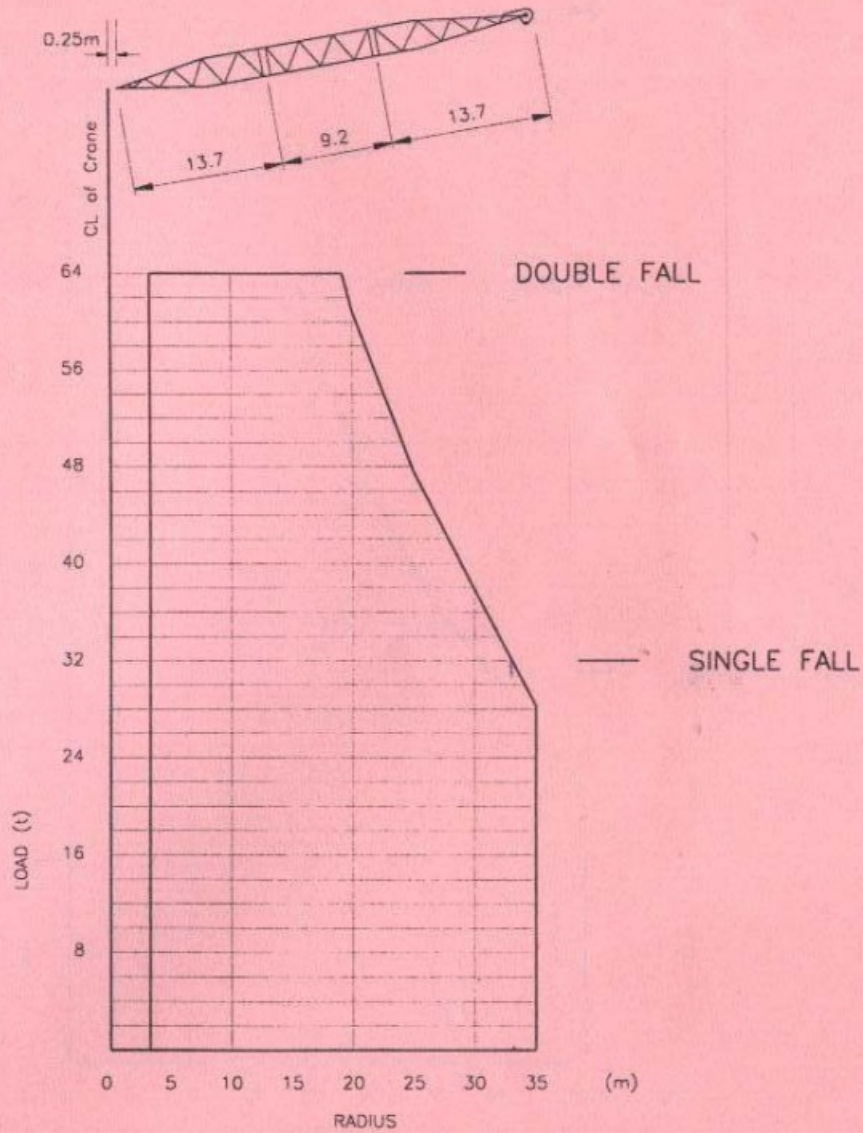

LOAD CHART 35.0m RADIUS BOOM									
RADIUS (m)	3.3	10.0	15.0	19.2	20.0	25.0	30.0	32.5	35.0
LOAD (T)	64.0	64.0	64.0	64.0	60.9	47.6	37.9	33.7	28.3
BOOM ANGLE (°)	86.2	75.5	67.2	59.8	58.4	48.5	36.9	29.6	20.1

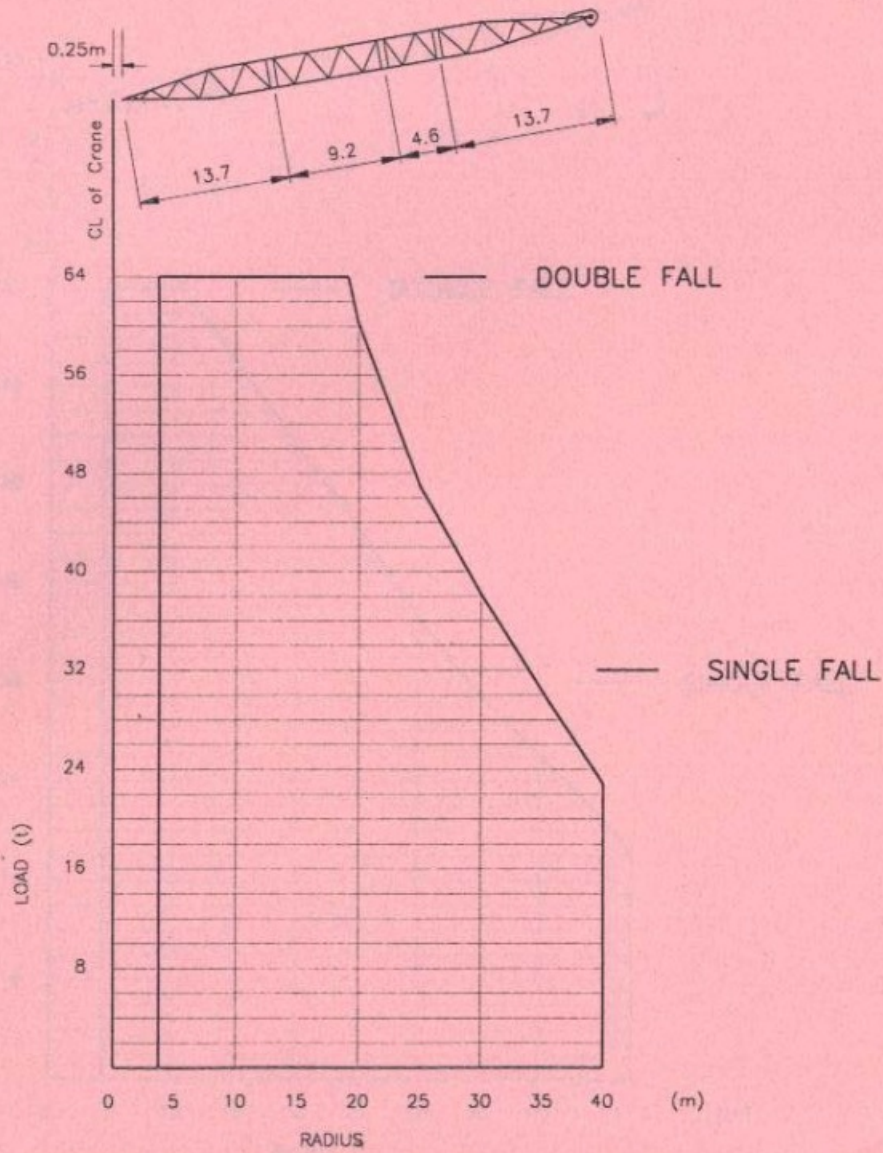

LOAD CHART 40.0m RADIUS BOOM									
RADIUS (m)	3.7	10.0	15.0	19.2	20.0	25.0	30.0	35.0	40.0
LOAD (T)	64.0	64.0	64.0	64.0	60.3	47.0	38.2	30.3	22.8
BOOM ANGLE (°)	86.0	77.2	69.9	63.5	62.2	54.0	44.8	33.6	17.1

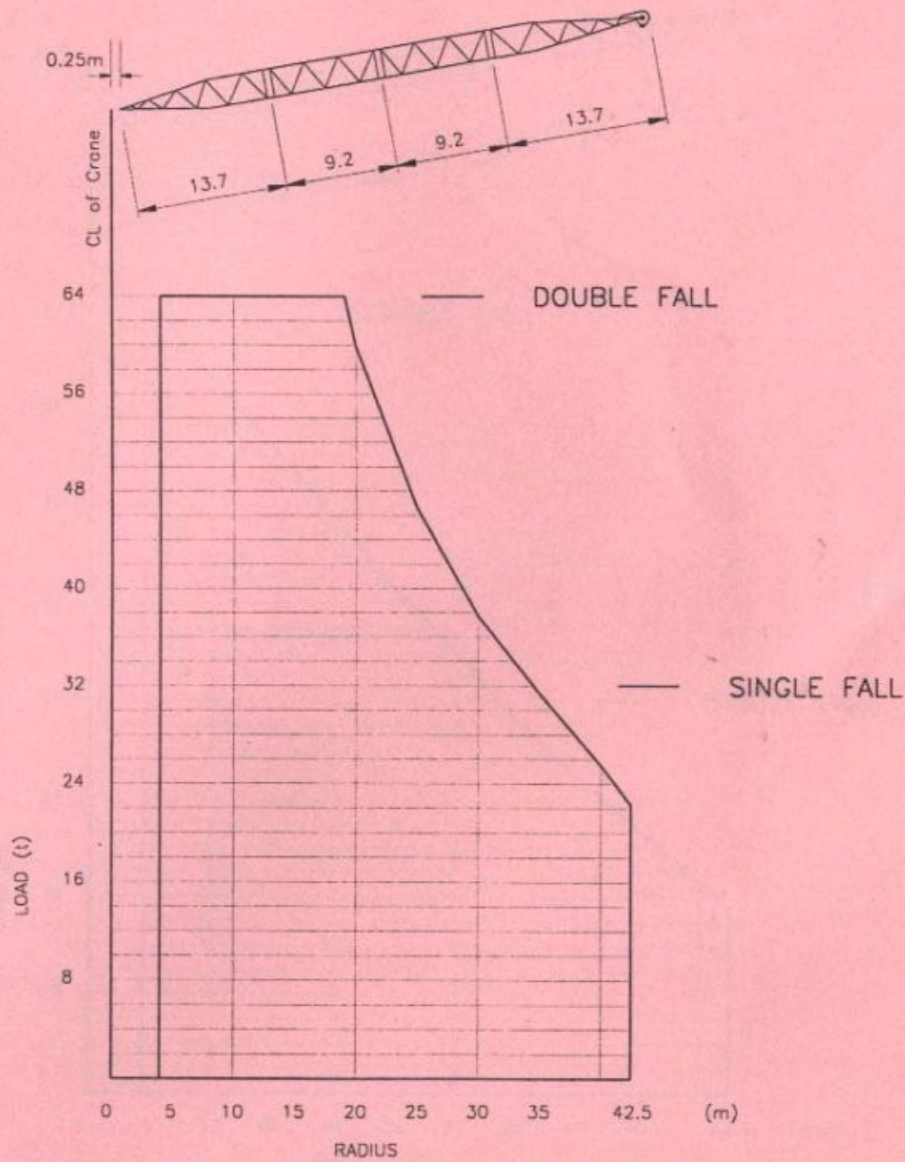

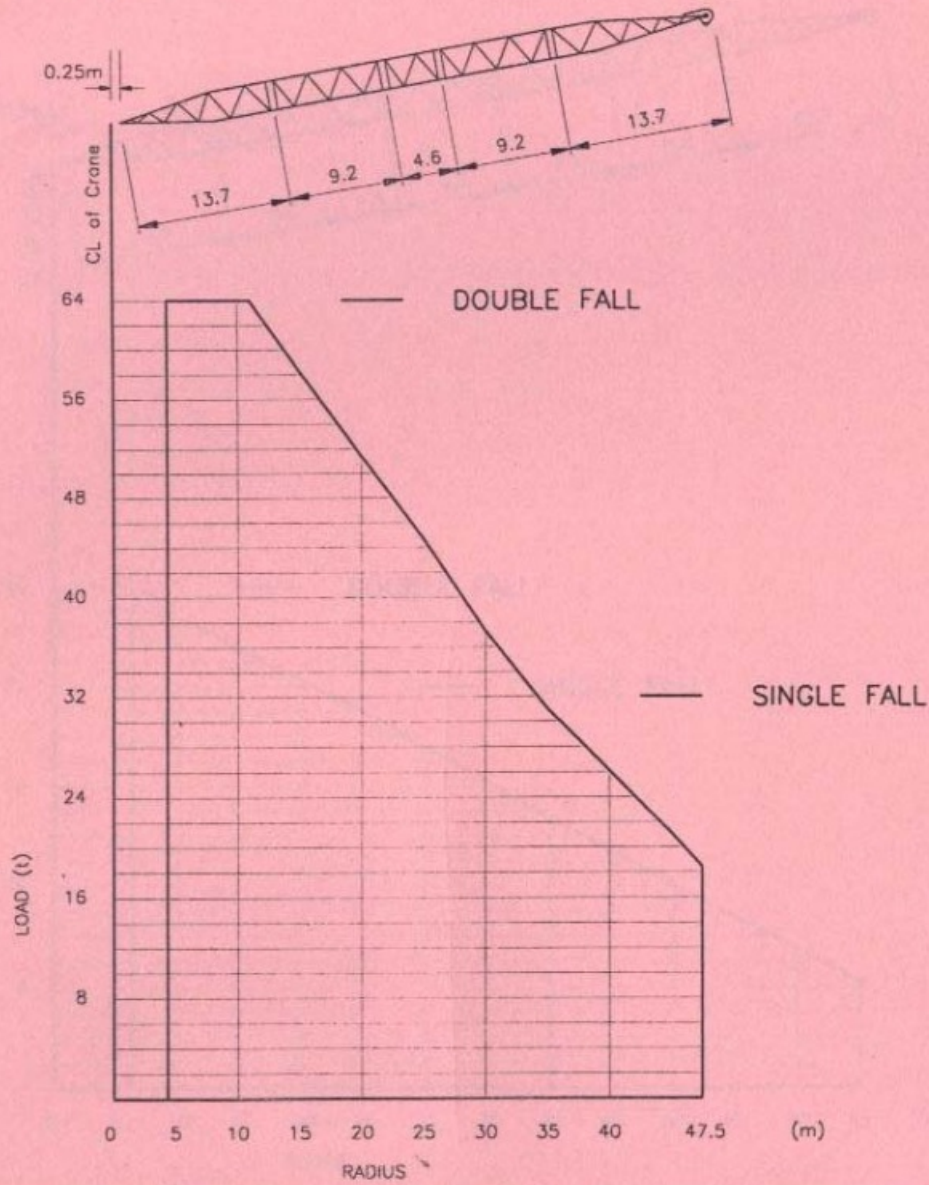

LOAD CHART 47.5m RADIUS BOOM

RADIUS (m)	4.3	10.0	11.0	15.0	20.0	25.0	30.0	35.0	40.0	45.0	47.5
LOAD (T)	64.0	64.0	64.0	58.3	51.4	44.7	37.3	31.0	26.1	21.1	18.4
BOOM ANGLE (°)	86.1	79.5	78.4	73.7	67.6	61.3	54.6	47.2	38.8	28.4	21.6

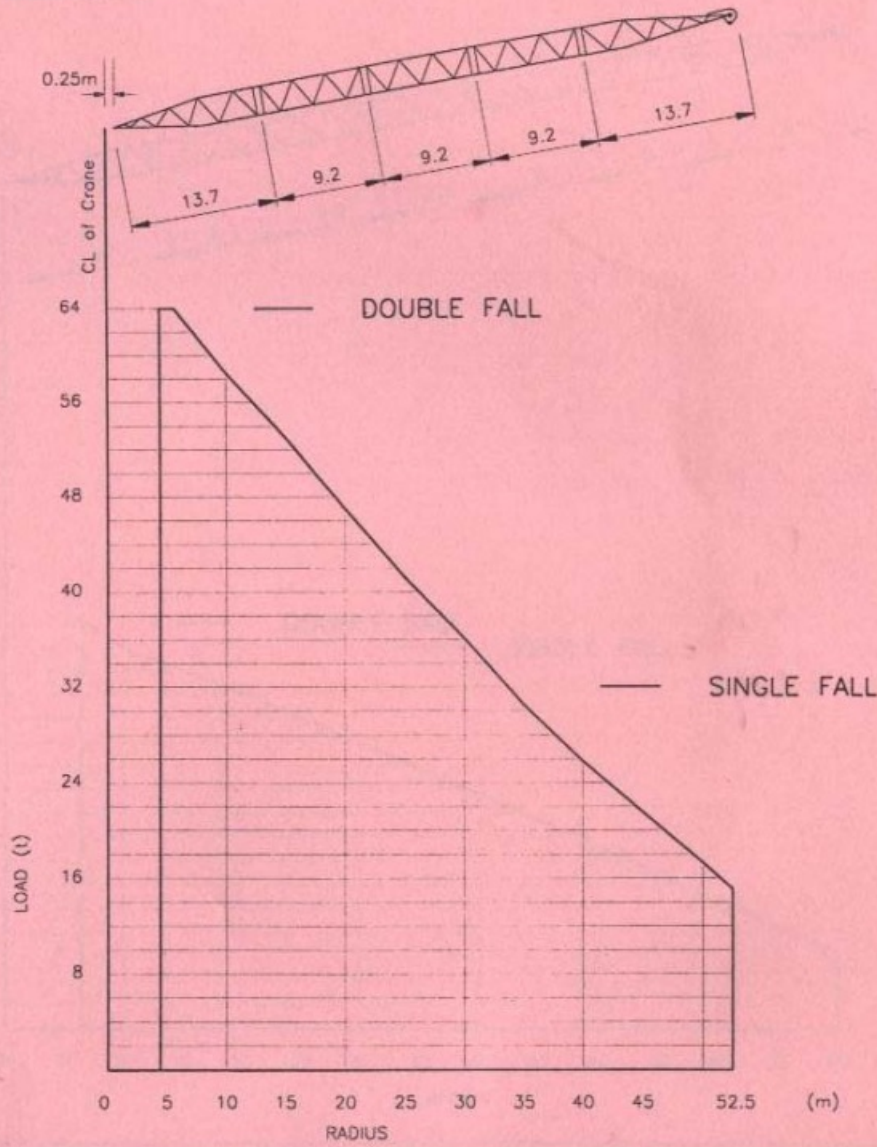

LOAD CHART 52.5m RADIUS BOOM

RADIUS (m)	4.4	5.6	10.0	15.0	20.0	25.0	30.0	35.0	40.0	45.0	50.0	52.5
LOAD (T)	64.0	64.0	58.5	53.0	47.0	41.2	36.1	30.5	25.8	21.5	17.3	15.1
BOOM ANGLE (°)	86.3	85.0	80.4	75.1	69.6	63.9	57.9	51.5	44.5	36.4	26.2	19.4

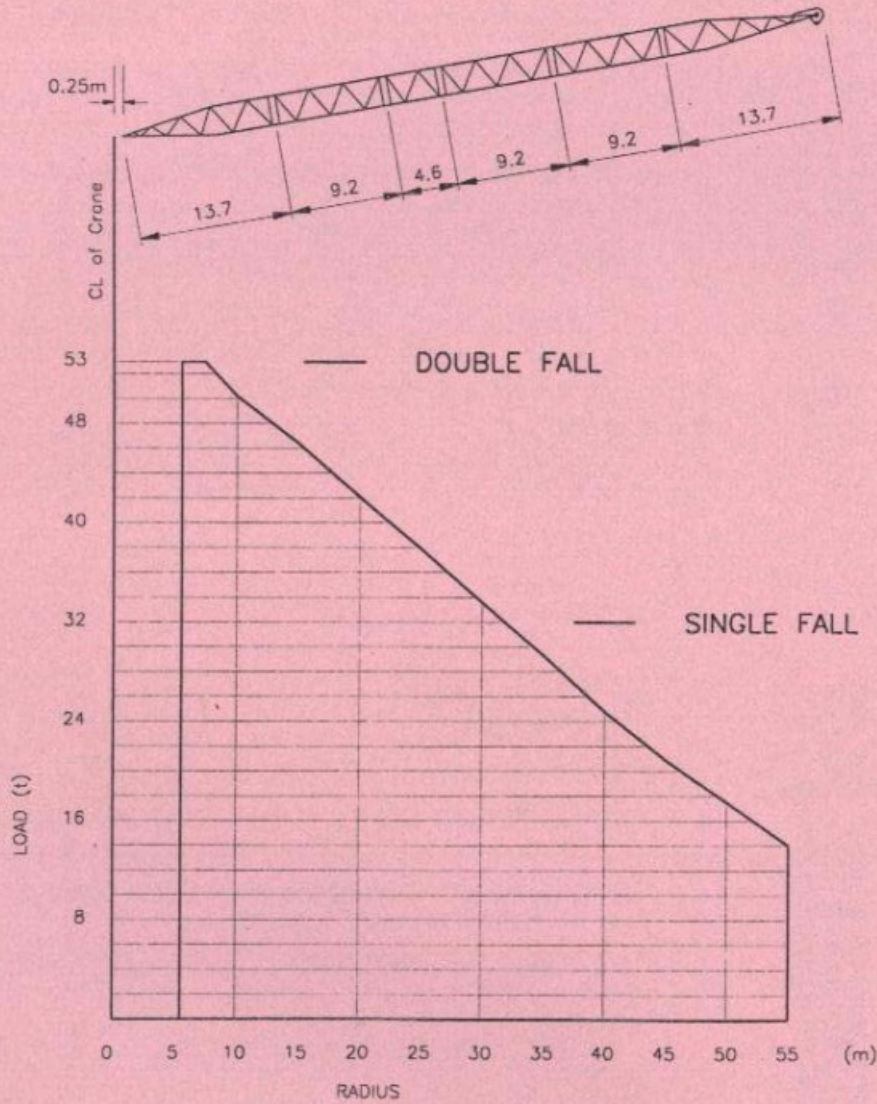

LOAD CHART 55.0m RADIUS BOOM												
RADIUS (m)	5.5	7.4	10.0	15.0	20.0	25.0	30.0	35.0	40.0	45.0	50.0	55.0
LOAD (T)	85.5	83.7	81.2	76.3	71.2	66.1	60.7	55.0	48.8	42.0	34.2	24.2
BOOM ANGLE (°)	53.0	53.0	50.2	46.4	42.1	37.9	33.6	29.3	24.8	20.9	17.5	14.0

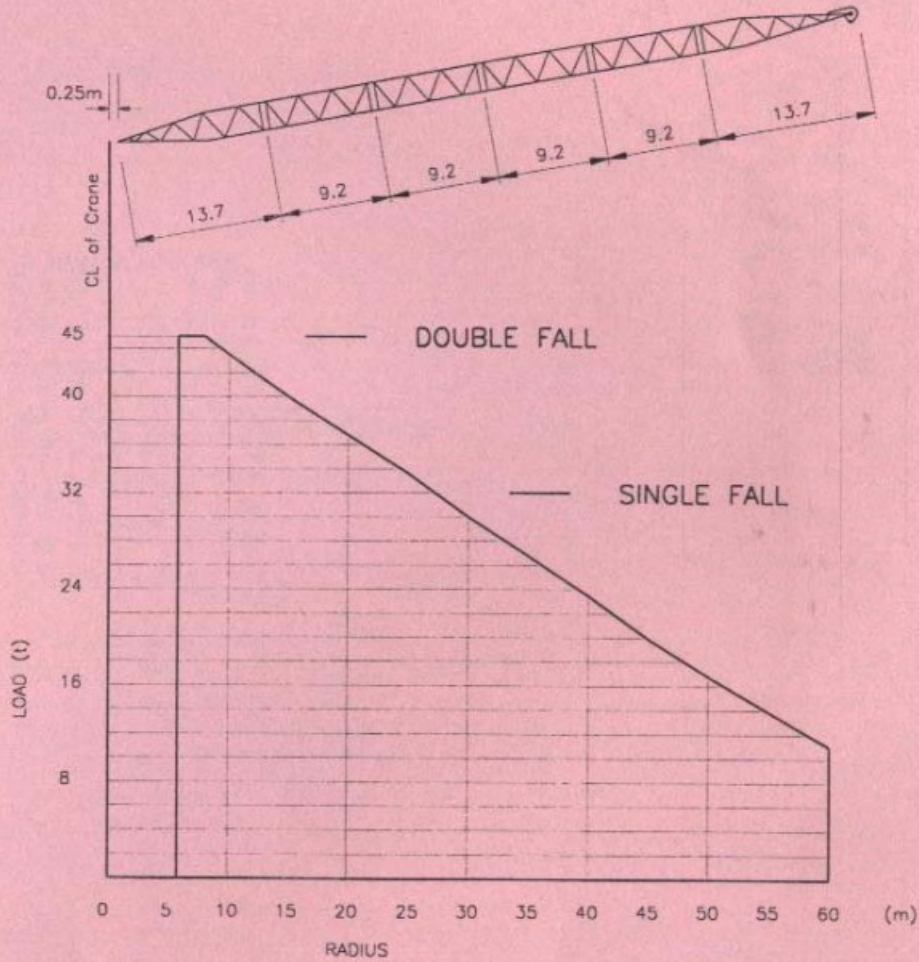

LOAD CHART 60.0m RADIUS BOOM													
RADIUS (m)	5.8	8.0	10.0	15.0	20.0	25.0	30.0	35.0	40.0	45.0	50.0	55.0	60.0
LOAD (T)	45.0	45.0	43.5	40.0	32.6	23.6	18.0	14.8	12.5	10.9	9.6	8.6	7.8
BOOM ANGLE (°)	85.6	83.6	81.8	77.3	70.8	65.0	60.0	56.0	52.3	49.0	46.0	43.2	40.6

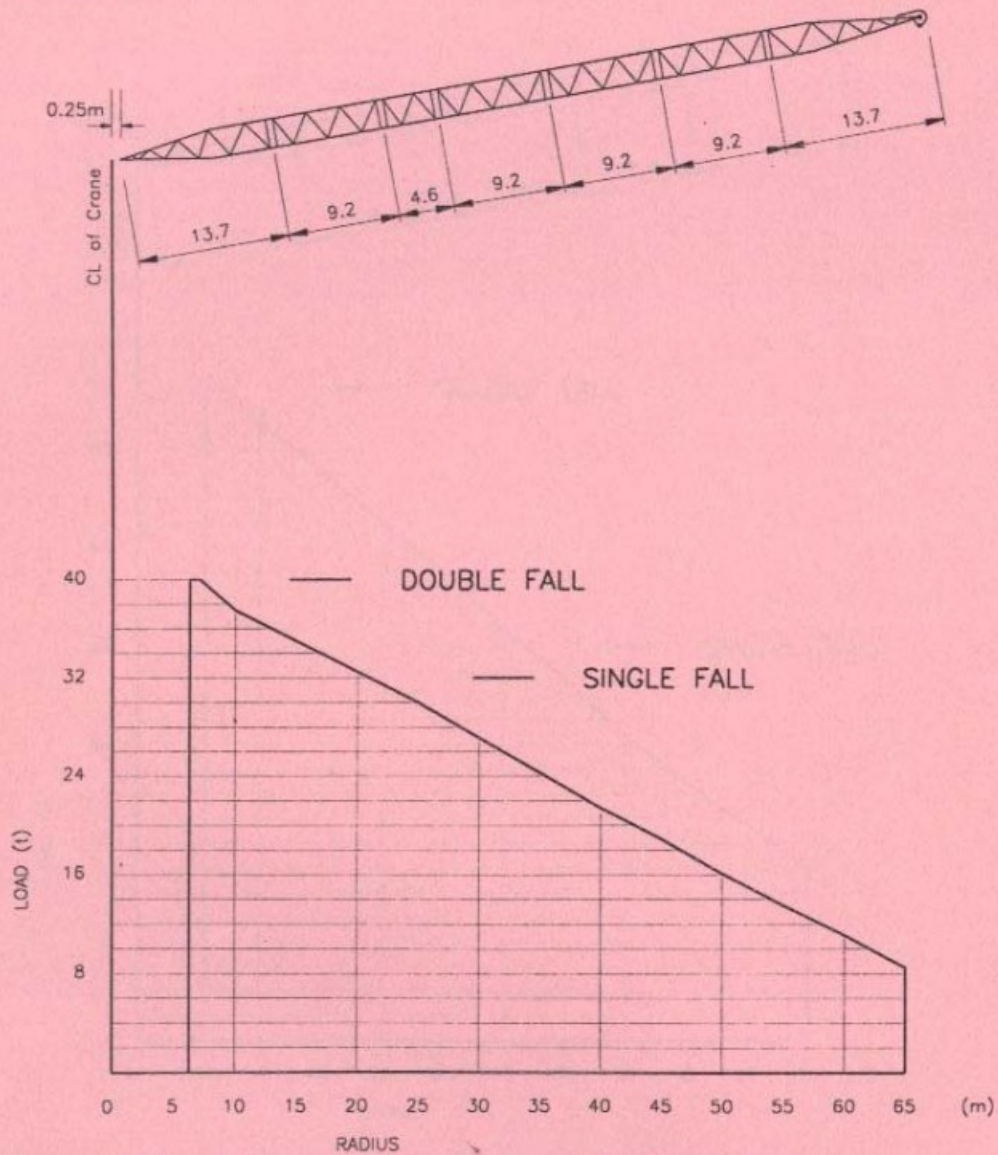

LOAD CHART 65.0m RADIUS BOOM

RADIUS (m)	6.3	7.1	10.0	15.0	20.0	25.0	30.0	35.0	40.0	45.0	50.0	55.0	60.0	65.0
LOAD (T)	40.0	40.0	37.5	35.0	32.5	30.0	27.1	24.3	21.4	18.9	16.1	13.5	11.1	8.5
BOOM ANGLE (°)	85.5	84.8	82.4	78.1	73.8	69.4	64.9	60.2	55.3	50.0	44.3	37.9	30.4	20.7

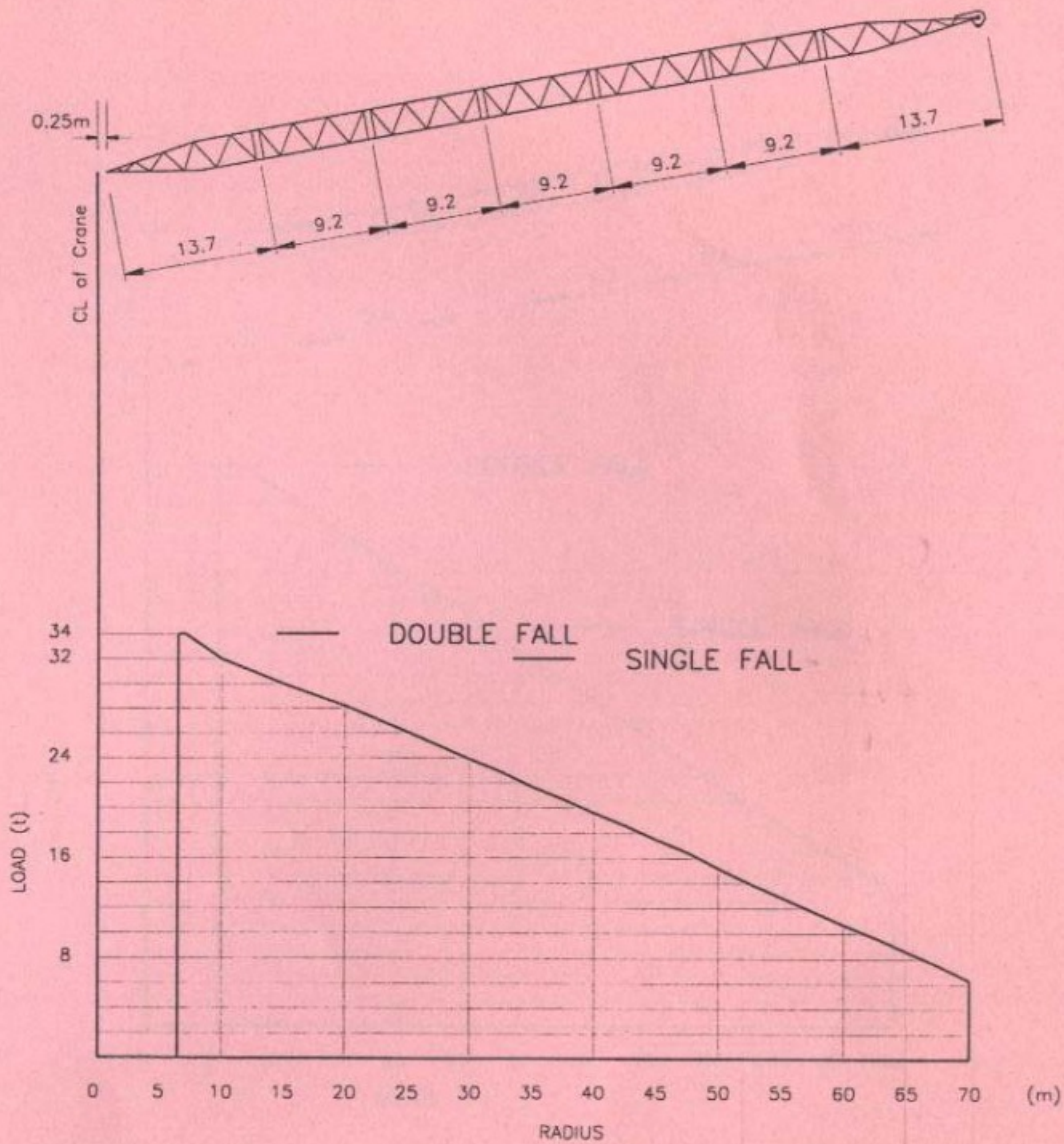

LOAD CHART 70.0m RADIUS BOOM														
RADIUS (m)	6.5	7.1	10.0	15.0	20.0	25.0	35.0	40.0	45.0	50.0	55.0	60.0	65.0	70.0
LOAD (T)	34.0	34.0	32.0	30.0	28.2	26.1	21.7	19.6	17.5	15.2	12.9	10.7	8.6	6.3
BOOM ANGLE (°)	85.6	85.1	82.8	78.9	74.9	70.9	62.2	57.7	53.0	47.9	42.3	36.1	28.8	19.1

900-70-32T-A

8. 其他证照资料

制造许可证:

3.25-6H

CERTIFICATE

OF COMPLIANCE

生产证明



LOT 42, PEJARAN BUNGA TAMUNG 2
SENAWANG INDUSTRIAL PARK
70400, SEREMBAN
NEGERI SEMBILAN, MALAYSIA
TEL : (606) 878 8888
FAX : (606) 878 8888
E-MAIL : admin@favellefavco.com.my

Certificate No : FFCM/06-1382
证明编号 : FFCM/06-1382

PROJECT : TOWER CRANE
项目 : 塔式起重机

Description 说明 :

CRANE MODEL : M900D S/NO. 1382
塔机型号 : M900D, 序号 1382
MANUFACTURED IN OUR FABRICATION
由我们公司马来西亚制造厂于2006年11月制作
YARD, SENAWANG, NEGERI SEMBILAN, MALAYSIA
IN NOVEMBER 2006

该塔机已经过严格检测测试, 各方面都符合合同要求, 特此证明。
We certify that the crane has been inspected and conform
in all respects to the requirements of the contract order.

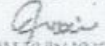
Signed:  Date: 30/11/2006
签名: MR LIM KUAN KHONG 日期:
ASSISTANT QA/QC MANAGER

For and on behalf of : FAVELLE FAVCO CRANES (M) SDN. BHD.
代表: FAVELLE FAVCO CRANES (M) SDN.BHD.

3,25-6#

CERTIFICATE
OF
QUANTITY

合格证

FVELLE FAVCO
The Cranemakers

LOT 42, PERSIARAN BUNGA TANJUNG 2
SENAWANG INDUSTRIAL PARK
70400, SEREMBAN
NEGERI SEMBILAN, MALAYSIA.
TEL : (606) 676 8866
FAX : (606) 676 8888
E-MAIL : admin@favellefavco.com.my

Certificate No : FFCM/06-1382

PROJECT : TOWER CRANE

Description :

CRANE MODEL : M900D S/NO. 1382

1) MACHINERY DECK	14,550KG	
2) CABIN	1,250KG	
3) WINCH & POWERPACK	16,000KG	
4) SLEW MOUNT	7,300KG	
5) BOOM BOTTOM (13.7M)	2,890KG	
6) BOOM TOP (13.7M)	2,610KG	
7) BOOM EXT. (9.2M)	1,700KG	(2 UNITS)
8) BOOM EXT. (4.6M)	995KG	
9) MAST	9,400KG	
10) BRIDLE	1,500KG	
11) HOOK	1,500KG	
12) CLIMBING CYLINDER	3,500KG	(2 UNITS)

We certify that the crane has been inspected and conform in all respects to the requirements of the contract order.

Signed : *Lim Yin Khong* Date : 30/11/2006
MR LIM YIN KHONG
ASSISTANT QA/QC MANAGER
For and on behalf of : FAVELLE FAVCO CRANES (M) SDN. BHD.



备案证书或IC卡:

上海市建筑起重机械产权备案登记证

设备信息栏

编号:沪-T-05109

设备名称:塔式起重机

产权单位:上海市机械施工集团有限公司

型号规格:M900D

单位地址:嘉定区顺达路615号

制造单位:Favelle Favco 起重机公司 (马来西亚)

出厂编号:1382

登记机关:上海市建设安全协会

出厂日期:2006年11月30日

上海市建筑起重机械
产权备案登记专用章
2016年06月20日

特种设备生产许可证编号:

FFCM//06-1382

登记证编号:T004351